

FM492

Cast Iron Check Valve

PN16

Features & Benefits

- Check valves permit flow in one direction only and close automatically if flow reverses
- Entirely automatic in action, depending upon pressure and velocity of flow within the line to perform their functions of opening and closing
- Swing pattern, metal faced disc

Materials

PART	MATERIAL	SIZES
Body	Cast Iron BS EN 1561 GJL-250	All
Cap	Cast Iron BS EN 1561 GJL-250	All
Disc	Cast Iron BS EN 1561 GJL-250	All
Body Seat Ring	Bronze BS EN 1982 CC491K	All
Disc Ring	Bronze BS EN 1982 CC491K	All
Hinge Pin Bush	Bronze BS EN 1982 CC491K	All
Hinge Pin Plug	Bronze BS EN 1982 CC491K	All
Hinge Pin	Stainless Steel Type 304	50 - 100
Hinge Pin	13% Cr.Steel AISI Type 410	125 - 300
Cap Bolts	Steel BS 3692 Gr.8.8	All
Cap Bolt Nuts	Steel BS 3692 Gr.8	All
Gasket	Asbestos Free	All
Body Plate	Aluminium	All

Dimensions & Weights

SIZE (mm)	WEIGHT (kg)	A (mm)	E (mm)
50	11.3	203	113
65	15.6	216	126
80	19.3	241	136
100	26.6	292	153
125	44	330	186
150	55.5	356	207
200	119	495	250
250	175	622	352
300	263	698	397



Dimensional Drawing

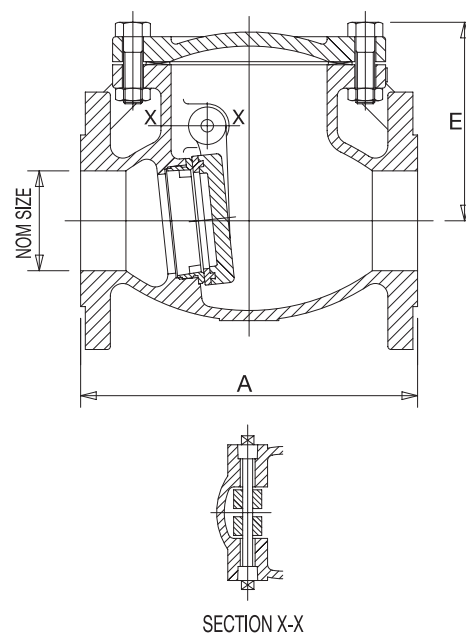

Pressure/Temperature Ratings

TEMPERATURE (°C)	-10 to 100	220
PRESSURE (BAR)	16	12.1

Intermediate pressure ratings shall be determined by interpolation.

PRESSURE RATING: PN16

TEMPERATURE OPERATING RANGE: -10 to 220°C

UK END CONNECTION: Flanged BS EN 1092-2

OPERATOR: Swing Type Check Valve

SPECIFICATION: Valves are manufactured in accordance with BS EN 12334: 2001.

End flanges conform to BS EN 1092-2 with raised face and are normally supplied drilled.

This valve is not suitable for use on Group 1 gases or unstable fluids, as defined by the Pressure Equipment Directive 2014/68/EU.*

* See page 257 for more information