

D7

Bronze Globe Valve

PN32

Features & Benefits

- Crane bronze globe valves are highly efficient for throttling because seat and disc designs provide flow characteristics with proportionate relationships between valve lift and flow rate

Materials

NO.	PART	MATERIAL	SIZES
1	Body	Bronze BS EN 1982 CC491K	All
2	Bonnet	Bronze BS EN 1982 CC491K	All
3	Stem	Brass BS EN 12163 CW721R	1/4 - 2
3	Stem	Bronze BS EN 1982 CC491K	2 1/2 & 3
4	Disc	PTFE - 25% Glass Filled	All
5	Disc Holder	Bronze BS EN 1982 CC491K	1 1/4 - 3
5	Disc Holder	Brass BS EN 12164 CW617N	1/4 - 1
6	Union Ring	Bronze BS EN 1982 CC491K	1/4, 3/8, 1/2 & 2
6	Union Ring	Brass BS EN 12164 CW617N	3/4 - 1 1/2
7	Packing	Asbestos Free	All
8	Packing Gland	Brass BS EN 12164 CW614N	All
9	Packing Nut	Brass BS EN 12164 CW614N	1/4 - 1 1/2
9	Packing Nut	Bronze BS EN 1982 CC491K	2 - 3
10	Washer	Brass BS EN 12164 CW614N	1/4 - 2
11	Disc Ret'ng Nut	Brass BS EN 12164 CW614N	1/4 - 2
11	Disc Ret'ng Nut	Bronze BS EN 1982 CC491K	2 1/2 & 3
12	Handwheel	Aluminium	1/4 - 2
12	Handwheel	Malleable Iron BS EN 1562 GJMB-300-6	2 1/2 & 3
13	Handwheel Nut	Brass BS EN 12164 CW614N	All
14	ID Plate	Aluminium	All
15	Disc Stem Ring	Brass BS EN 12163 CW721R	1/4 - 2
15	Disc Stem Ring	Bronze BS EN 1982 CC491K	2 1/2 & 3
16	Bonnet Stud	Steel BS 970 070M20	2 1/2 & 3
17	Bonnet Stud Nut	Steel BS 4190 Gr.4	2 1/2 & 3
18	Gasket	Asbestos Free	2 1/2 & 3

Dimensions & Weights

SIZE (inch)	WEIGHT (kg)	A (mm)	B (mm)	C (mm)
1/4	0.5	52	100	52
3/8	0.49	52	100	52
1/2	0.73	62	101	52
3/4	1.09	74	115	52
1	1.74	90	125	70
1 1/4	2.44	100	150	70
1 1/2	3.32	115	159	92
2	5.54	136	191	103
2 1/2	10.9	184	278	152
3	16.4	210	308	178



Dimensional Drawing

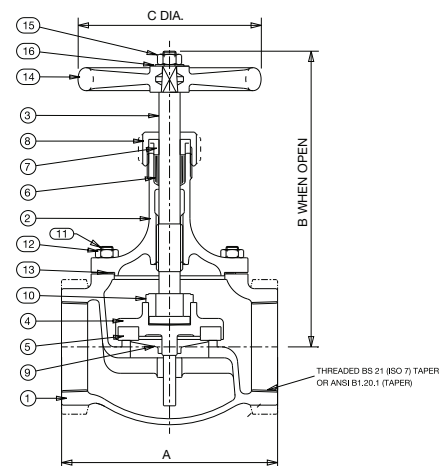
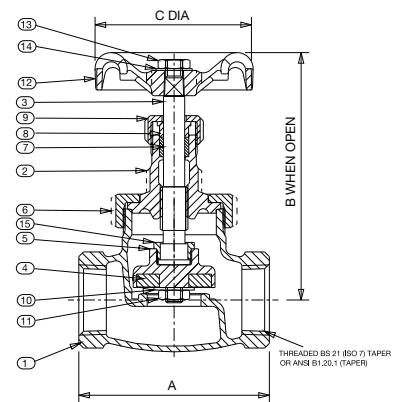

PRESSURE RATING: PN32

TEMPERATURE OPERATING RANGE: -10 to 198°C

UK END CONNECTION: BS 21 Taper

US END CONNECTION: ANSI B1.20.1

OPERATOR: Handwheel.

AVAILABLE OPTIONS: P150 Locking Device

SPECIFICATION: Valves are manufactured in accordance with BS 5154 PN32 for Series B ratings.

Design incorporates a disc holder with on sizes 1/4" to 2" slips on to stem, and on sizes 2 1/2" and 3" is retained by a threaded ring. Sizes 1/4" to 3" BS 21 versions BSI Kitemarked.

Body seat is integral of the semi-crown type. Sizes 1/4" to 2" have union bonnet and sizes 2 1/2" and 3" have a bolted bonnet. Valves having ANSI threads also generally conform to MSS SP-80.

This valve is not suitable for use on group 1 gases or unstable fluids, as defined by the Pressure Equipment Directive 97/23/EC.*

* See page 251 for more information